

# Enhanced Adaptive Acknowledgement for Mobile Ad Hoc Network

B.Sowndarya<sup>1</sup>, G.V.Suresh<sup>2</sup>, O.SrinivasaReddy<sup>3</sup>, Dr.Sai Satyanarayana Reddy<sup>4</sup>

<sup>1</sup> M.Tech, CSE, LBRCE, Mylavaram

<sup>2</sup> Associate Professor, CSE, LBRCE, Mylavaram, India

<sup>3</sup> Assistant professor, CSE, LBRCE, Mylavaram, India

<sup>4</sup> Professor, CSE, LBRCE, Mylavaram, India

**Abstract**—A Mobile Ad Hoc Network (MANET) is a collection of mobile nodes (hosts) which communicate with each other via wireless links either directly or indirectly depending on other nodes. In recent years, the use of mobile ad hoc network (MANET) has been widespread in many applications, including some critical mission applications and as such security has become one of the major concerns in MANET. MANET does not require a fixed infrastructure and MANET originally developed on military use. However the open medium and wide distributions of nodes make to various types of malicious attacks. The self-configuring ability of nodes in MANET made it popular among critical mission applications like military use recovery. However, the open medium and wide distribution of nodes make MANET vulnerable to malicious attackers. In this case, it is crucial to develop an efficient intrusion detection mechanism to protect MANET from attacks. In this paper, we propose and implement a new intrusion detection system named Enhanced Adaptive Acknowledgment (EAACK) specially designed for MANET and compared to all contemporary approaches. The results will be positive performances of WATCHDOG, TWOACK and AACK in the cases are receiver collision, limited transmission power and false misbehavior report.

**Index Terms:** Digital signature, digital signature algorithm (DSA), Enhanced Adaptive Acknowledgment (AACK) (EAACK), Mobile Ad hoc Network (MANET).

## 1. INTRODUCTION

Mobile Adhoc Network (MANET) is collection of wireless mobile hosts (or nodes) that are free to in any directions at any speed. Mobile nodes are equipped with a wireless transmitter and a receiver that communicate directly with each other or forward message through other nodes. One of the major advantages of mobile networks is to allow different nodes for data communications and still maintain their mobility. However, this communication is limited to the range of transmitters. It means that two nodes cannot communicate with each other when the distance between the two nodes is beyond the communication range of their own. MANET solves this problem by allowing intermediate nodes to relay data transmissions. This is achieved by dividing MANET into two types of networks such as single-hop and multihop. In a single-hop network, all nodes within the same radio range communicate directly with each other. But in a multihop network, nodes rely on other intermediate nodes to transmit if the end point node is out of their radio communication range. MANET is capable

of operating a self-maintaining and self-organizing network without the support of any fixed infrastructure. MANET does not require expensive base stations of infrastructure dependent network (single-hop wireless networks)[16]. As MANETs have different characteristics from wired networks and even from single-hop wireless networks, there are more number of new challenges interrelated to security issues that need to be addressed. Initially, MANET was designed for military applications, but, in recent years, has found new usage. For example, search and rescue mission, data collection, virtual classes and conferences where laptops, PDA or other mobile devices are in wireless communication. Since MANET is being used wide spread, security has become a very important issue [2]. In general, MANETs are vulnerable based on the basic characteristics such as open medium, changing topology, absence of infrastructure, restricted power supply, and scalability. In such case, Intrusion detection can be defined as a process of monitoring activities in a system which can be a computer or a network. The mechanism that performs this task is called an Intrusion Detection System. The rest of the article is organized as follows. Section 2 presents the review of about SIDS in MANETs. Section 3 presents the IDS architecture for enhancing security level of MANETs based on security attributes and various algorithms, namely RSA and DSA. Finally, conclusion and discussion are presented in Section 4.

## 2. BACKGROUND

### 2.1 Discovering malicious nodes

**a) Watchdog:** It is very popular and highly efficient IDS for improving the throughput of network with the presence of malicious nodes. This IDS can be classified into two methods such as Watchdog and Path rater. It is responsible for discovering malicious node misbehaviors in the network. Watchdog detects malicious misbehaviors by listening to its next hop's transmission in the network. If a Watchdog IDS overhears that its next node fails to forward the packet within a certain period of time, it increases its failure counter. Whenever a node's failure counter exceeds a predefined threshold value, the Watchdog node reports it as misbehaving. In this case, the Path rater cooperates with the routing protocols to avoid the reported nodes in future transmission. The Watchdog-IDS fails to discover malicious nodes in the following situations: 1) ambiguous

collisions; 2) receiver collisions; 3) limited transmission power; 4) false misbehavior report; 5) collusion; and 6) partial dropping.

**b) TWOACK:** With respect to the six weaknesses of the Watchdog scheme, many researchers proposed new approaches to solve these issues. TWOACK proposed by Liu *et al.* is one of the most important approaches among them. On Fig. a. TWOACK scheme: Each node is required to send back an acknowledgment packet to the node that is two hops away from it. the contrary to many other schemes, TWOACK is neither an enhancement nor a Watchdog-based scheme. Aiming to resolve the receiver collision and limited transmission power problems of Watchdog, TWOACK detects misbehaving links by acknowledging every data packet transmitted over every three consecutive nodes along the path from the source to the destination. Upon retrieval of a packet, each node along the route is required to send back an acknowledgment packet to the node that is two hops away from it down the route. TWOACK is required to work on routing protocols such as Dynamic Source Routing (DSR). The working process of TWOACK is shown in Fig. a: Node A first forwards Packet 1 to node B, and then, node B forwards Packet 1 to node C. When node C receives Packet 1, as it is two hops away from node A, node C is obliged to generate a TWOACK packet, which contains reverse route from node A to node C, and sends it back to node A. The retrieval of this TWOACK packet at node A

indicates that the transmission of Packet 1 from node A to node C is successful. Otherwise, if this TWOACK packet is not received in a predefined time period, both nodes B and C are reported malicious. The same process applies to every three consecutive nodes along the rest of the route. The TWOACK scheme successfully solves the receiver collision and limited transmission power problems posed by Watchdog. However, the acknowledgment process required in every packet transmission process added a significant amount of unwanted network overhead. Due to the limited battery power nature of MANETs, such redundant transmission process can easily degrade the life span of the entire network. However, many research studies are working in energy harvesting to deal with this problem.

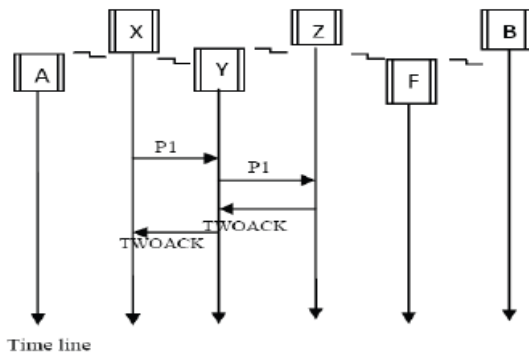

Fig. a. TWOACK IDS for MANETs

**c) AACK:** It is same as TWOACK IDS, AACK IDS is an acknowledgment-based network layer IDS. It can be

treated as a combination of an IDS called TACK (identical to TWOACK) and an end-to-end acknowledgment IDS called Acknowledge (ACK). Compared to TWOACK IDS, AACK IDS reduced network overhead. The end-to-end ACK IDS is shown in Fig. b. The source node A sends out Packet 1 without any overhead. All the intermediate nodes simply forward this packet. When the destination node B receives Packet 1, it is required to send back an ACK acknowledgment packet to the source node A along the reverse order of the same path. Within a predefined time slot, if the source node A receives this ACK packet, then the packet transmission from node A to node B is successful. Otherwise, the source node A will switch to TACK IDS by sending out a TACK packet. The concept of adopting a hybrid IDS in AACK greatly reduces the network overhead, but both TWOACK and AACK still suffer from the problem that they fail to detect malicious nodes with the presence of false misbehavior report and fake ACK packets.

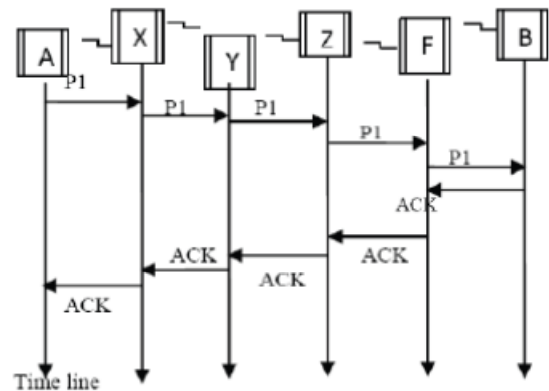

Fig. b End-to-End ACK IDS for MANETs

In fact, many of the existing IDSs in MANETs adopt an acknowledgment-based scheme, including TWOACK and AACK. The functions of such detection schemes all largely depend on the ACK packets. Hence, it is crucial to guarantee that the acknowledgment packets are valid and authentic. To address this concern, a digital signature is adopted in recent secure IDS named Enhanced AACK (EAACK).

### 3. PROPOSED SYSTEM

Secure IDS architecture (EAACK) introduced to improve the security level of MANETs based on security attributes and various algorithms, namely RSA and DSA. EAACK is designed to tackle three out of six weaknesses of Watchdog IDS, namely, 1) Receiver collision, 2) Limited transmission power, 3) False misbehavior.

**1) Receiver collisions:** Example of receiver collisions, shown in Fig. c, after node X sends Packet 1 to node Y, it tries to overhear if node Y forwarded this packet to node Z; meanwhile, node F is forwarding Packet 2 to node Z. In such case, node X overhears that node Y has successfully forwarded Packet 1 to node Z but failed to detect that node Z did not receive this packet due to a collision between Packet 1 and Packet 2 at node Z.

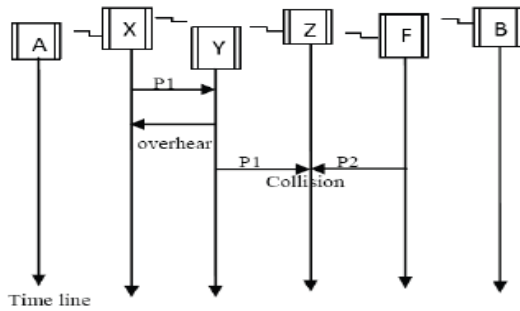

Fig c. Receiver collisions in MANETs

2) **Limited transmission power:** Example of Limited power, shown in Fig. d, in order to manage the battery resources in MANETs, node Y limits its transmission power so it is very strong to be overheard by node X after transmitting the packet (P1) to node Z, but too weak to reach node Z because of transmission power can be reduced.

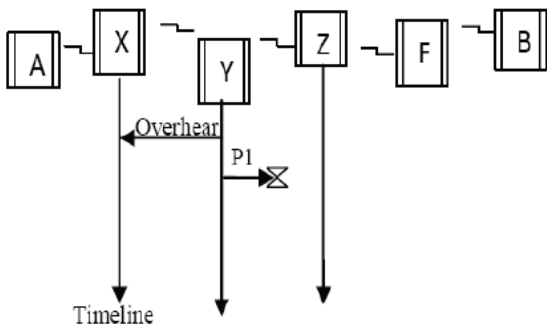

Fig d. Limited transmission power in MANETs

3) **False misbehavior:** Example of false misbehavior in MANETs, shown in Fig. e, Even though node X and Y forwarded Packet 1 to node Z successfully, node X still inform node Y as misbehaving, as shown in Fig. e. Due to the open medium and remote distribution of typical MANETs, attackers can easily capture and compromise one or two nodes to achieve this false misbehavior report attack. As discussed in previous sections, TWOACK and AACK solve two of these three weaknesses, namely, receiver collision and limited transmission power. However, both of them are vulnerable to the false misbehavior attack. In order to solves not only receiver collision and limited transmission power but also the false misbehavior problem to launch Secure IDS architecture (EAACK).

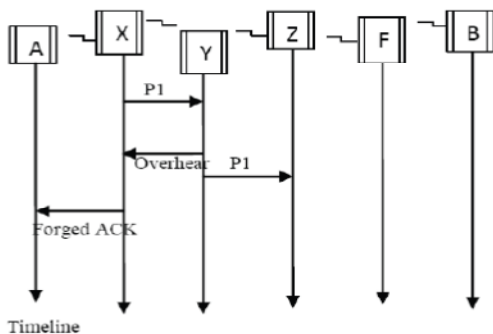

Fig.e. False misbehavior in MANETs

4) **A Secure IDS description:**

EAACK is consisted of three major parts, namely, ACK, secure ACK (S-ACK), and misbehavior report authentication (MRA). In order to distinguish different packet types in different schemes to include a 2-b packet header in EAACK. According to the Internet draft of DSR, there is 6 b reserved in the DSR header. In EAACK, use 2 b of the 6 b to flag different types of packets.



Fig. 7 EAACK protocol in MANETs

In this secure IDS, It is assumed that the link between each node in the network is bidirectional. Furthermore, for each communication process, both the source node and the destination node are not malicious. All acknowledgment packets are required to be digitally signed by its sender and verified by its receiver.

- I) **ACK:** ACK is basically an end-to-end ACK IDS. It acts as a part of the hybrid IDS in EAACK, aiming to reduce network overhead when no network misbehavior is detected. Consider the scenario source node first sends out an ACK data packet to the destination node D. If all the intermediate nodes along the route between nodes S and D are cooperative and node D successfully receives packet, node D is required to send back an ACK acknowledgment packet along the same route but in a reverse order. Within a predefined time period, if node S receives packet, then the packet transmission from node S to node D is successful. Otherwise, node S will switch to S-ACK mode by sending out an S-ACK data packet to detect the misbehaving nodes in the route.
- II) **S-ACK:** It is an improved version of the TWOACK IDS [6]. The principle is to let every three consecutive nodes work in a group to detect misbehaving nodes. For every three consecutive nodes in the route, the third node is required to send an S-ACK acknowledgment packet to the first node. The intention of introducing S-ACK mode is to detect misbehaving nodes in the presence of receiver collision or limited transmission power.
- III) **MRA :** Unlike the TWOACK IDS, where the source node immediately trusts the misbehavior report, EAACK requires the source node to switch to MRA mode and confirm this misbehavior report. This is a vital step to detect false misbehavior. The MRA field is designed to resolve the weakness of Watchdog when it fails to detect misbehaving nodes with the presence of false misbehavior. To initiate the MRA mode, the source node first searches its local knowledge base and seeks for an alternative route to the destination node. If there is no other that exists, the source node starts a DSR routing request to find another route. Due to the nature of MANETs, it is common to find out multiple routes between two nodes. When the destination node receives an MRA packet, it searches its local knowledge base and compares if the reported packet

was received. If it is already received, then it is safe to conclude that this is a false misbehavior report and whoever generated this report is marked as malicious. Otherwise, the misbehavior report is trusted and accepted. By the adoption of MRA scheme, EAACK is capable of detecting malicious nodes despite the existence of false misbehavior report.

**IV) Digital Signature:** EAACK is an acknowledgment-based IDS. All three parts of EAACK, namely, ACK, S-ACK, and MRA, are acknowledgment-based detection schemes. They all rely on ACK packets to detect misbehaviors in the network. Thus, it is extremely important to ensure that all acknowledgment packets in EAACK are authentic and untainted. Otherwise, if the attackers are smart enough to forge acknowledgment packets, all of the three schemes will be vulnerable. To overcome this problem, need to incorporate digital signature in secure IDS. In order to ensure the integrity of the IDS, EAACK requires all ACK packets to be digitally signed before they are sent out and verified until they are accepted

**V) Secure IDS in DSA and RSA:**

The signature size of DSA is much smaller than the signature size of RSA. So the DSA scheme always produces slightly less network overhead than RSA does. However, it is interesting to observe that the Routing Overhead differences between RSA and DSA schemes vary with different numbers of malicious nodes. Although the DSA scheme requires more computational power to verify than RSA, considering the tradeoff between battery power and performance, DSA is still preferable.

#### CONCLUSION

In this survey paper, a comparative study of Secure Intrusion- Detection Systems (SIDS) for discovering malicious nodes and attacks on MANETs is presented. Due to some special characteristics of MANETs, prevention mechanisms alone are not adequate to manage the secure networks. In this case detection should be focused as another part before an attacker can damage the structure of the system. we study about secure IDS named EAACK protocol specially designed for MANETs and in future it is required to compare against other popular mechanisms.

Security is major part in MANETS, hybrid cryptography architecture will tackle the issue in an efficient manner. This way we can better preserve battery and memory space of mobile nodes. In this research we continue the improvement of the existing IDSs over MANETS. In specific, we solve two problems of Watchdog technique, which considered to be the base technique that is used by many of the recently IDSs. Receiver collision and limited power transmission are the two main problems that we focused in this paper.

#### REFERENCES

- [1] D. Johnson and D. Maltz, "Dynamic Source Routing in *ad hoc* wireless networks," in *Mobile Computing*. Norwell, MA: Kluwer, 1996, ch. 5, pp. 153–181.
- [2] N. Kang, E. Shakshuki, and T. Sheltami, "Detecting misbehaving nodes in MANETS," in *Proc. 12th Int. Conf. iiWAS*, Paris, France, Nov. 8–10, 2010, pp. 216–222.
- [3] N. Kang, E. Shakshuki, and T. Sheltami, "Detecting forged acknowledgements in MANETS," in *Proc. IEEE 25th Int. Conf. AINA*, Biopolis, Singapore, Mar. 22–25, 2011, pp. 488–494.
- [4] K. Kuladmith, A. S. Timm-Giel, and C. G6rg, "Mobile *ad-hoc* communications in AEC industry," *J. Inf. Technol. Const.*, vol. 9, pp. 313–323, 2004.
- [5] J.-S. Lee, "A Petri net design of command filters for semiautonomous mobile sensor networks," *IEEE Trans. Ind. Electron.*, vol. 55, no. 4, pp. 1835–1841, Apr. 2008.
- [6] K. Liu, J. Deng, P. K. Varshney, and K. Balakrishnan, "An acknowledgment-based approach for the detection of routing misbehavior in MANETS," *IEEE Trans. Mobile Comput.*, vol. 6, no. 5, pp. 536–550, May 2007.
- [7] S. Marti, T. J. Giuli, K. Lai, and M. Baker, "Mitigating routing misbehavior in mobile *ad hoc* networks," in *Proc. 6th Annu. Int. Conf. Mobile Comput. Netw.*, Boston, MA, 2000, pp. 255–265.
- [8] Vijaya, K., "Secure 2Ack Routing Protocol In Mobile Ad Hoc Networks", TENCON 2008-2008 IEEE Region 10 Conference pages=1–7, year=2008, organization= IEEE
- [9] Liu, K. and Deng, J. and Varshney, P.K. and Balakrishnan, K., "An acknowledgment-based approach for the detection of routing misbehavior in MANETS", *Mobile Computing, IEEE Transactions* volume=6, number=5, pages=536–550, year=2007, publisher=IEEE.
- [10] Fall, K. and Varadhan, K., "The network simulator (ns-2)", URL: <http://www.isi.edu/nsnam/ns>, year=2007.
- [11] Gorantala, K., 'Routing protocols in mobile *ad-hoc* Networks', Master's Thesis in Computing Science, June, volume=15, year=2006, publisher=Citeseer.
- [12] Marina, M.K. and Das, S.R., "Ad hoc on-demand multipath distance vector routing", *Wireless communications and Mobile Computing* volume=6, number= 7, pages=969–988, year=2006, publisher=Wiley Online Library.